

**BRIAN MOORE CUSTOM GUITARS**  
**OWNER'S MANUAL**



**THE CARE AND MAINTENANCE OF YOUR  
BRIAN MOORE CUSTOM GUITAR**

**TABLE OF CONTENTS**

1. INTRODUCTION.....	1
2. PLUGGING IN.....	1
3. STRINGS AND SET UP.....	1
4. TUNERS.....	2
5. TRUSS ROD.....	2
6. PICKUPS.....	3
7. BRIDGES.....	3
a. Wilkinson Vibrato.....	3
b. Wilkinson Fixed.....	4
c. Tonepros.....	4
d. Floyd Rose.....	5
8. 13 PIN SYSTEM.....	5
9. REPAIRS/ WARRANTY.....	5
10. CONTROLS GUIDE.....	6
11. PICK UP CONFIGURATIONS.....	7
a. C-90.....	7
b. DC-1, C-55.....	8



**BRIAN MOORE CUSTOM GUITARS**  
**OWNER'S MANUAL**

**1. INTRODUCTION:**

Congratulations on the purchase of your new Brian Moore Custom Guitar. We have worked hard to craft one of the finest instruments available today, and we are sure you will be pleased with the results.

Like all fine instruments, your Brian Moore Guitar needs to be properly maintained to keep it functioning in top condition. The purpose of this booklet is to give you some tips on how to keep your guitar performing at it's best.

If you have any questions, are in need of technical assistance, or would like to schedule a repair, please contact us at 1-800-795-PLAY (7529), or on the internet at [info@brianmooreguitars.com](mailto:info@brianmooreguitars.com).

**2. PLUGGING IN:**

The output jack is located on the back of the guitar. If your guitar is equipped with a standard tremolo or fixed bridge (without Piezo), use a regular guitar cable with a standard 1/4" jack to plug from your guitar to your amplifier.

If your guitar is equipped with a piezo bridge, use the stereo Y cable, supplied in your case. Plug the single end into your guitar. The end marked "Magnetic" plugs into your amplifier, the end marked "Piezo" should be plugged into an acoustic amplifier or P.A. system.

If your guitar is equipped with a 13 pin system, follow the instructions for a piezo equipped guitar for the magnetic pick ups, and piezo. In addition run a 13 pin cable from the 13 pin jack, located on the back-bottom edge of the guitar, to your 13 pin sound module. You can also run the guitar with the 13 pin cable only. In this set up you can access the 13 pin sounds and the magnetic pick ups through the 13 pin cable. In this set up you will not be able to access the piezo output.

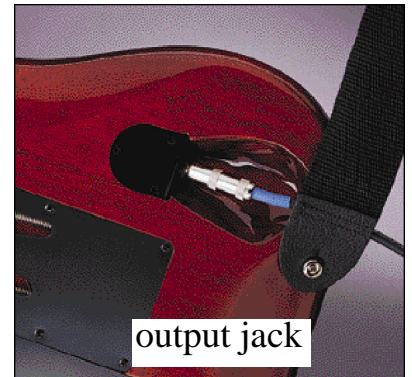

**3. STRINGS AND SET UP:**

Most of our guitars are made of wood. Wood being a natural, porous material will expand and contract with different environmental conditions. Over time this expanding and contracting can effect the playability of the guitar. As a result, it is recommended that from time to time the guitar be set up by a qualified technician.

The fingerboard should be oiled from time to time to prevent drying and cracking. Fingerboard oil is recommended, and is available at many musical instrument stores or by mail from Stewart- Macdonald's Guitar Supply. If fingerboard oil is not available, lemon oil for wood furniture will suffice.

Unless otherwise requested, your guitar has been set up with .009 - .042 gauge strings. If you want to change to a different gauge strings, your guitar will need to be set up for that particular gauge. It is recommended that this work be done by a qualified technician.

When changing strings, it is recommended that the strings be replaced one at a time, this insures that the neck relief does not change and allows a longer time between set ups. In the event that you need to remove all the strings at once for some reason (oiling the fingerboard, etc.), if your guitar is equipped with a vibrato bridge, place a piece of cardboard, a folded up rag, or some other soft material under the back of the bridge plate. This will keep the bridge from pressing down on the top of the guitar and damaging the finish.

The distance between the frets and the strings is referred to as the action. Low action (a small distance between strings and frets) makes the guitar easier and faster to play, since less force is required to press the



string down to the fret. This is usually preferred by players with a delicate touch who are interested in speed. Players with a more aggressive approach often prefer the action a little higher, giving the strings more room to vibrate and increasing sustain. To adjust the action on a tremolo bridge, turn the bridge height adjustment screws in front of the bridge. It is not recommended to adjust the height of the individual saddles. They have been pre-set to match the radius of the fingerboard. Imprecise adjustment will leave the strings at different heights from the frets.

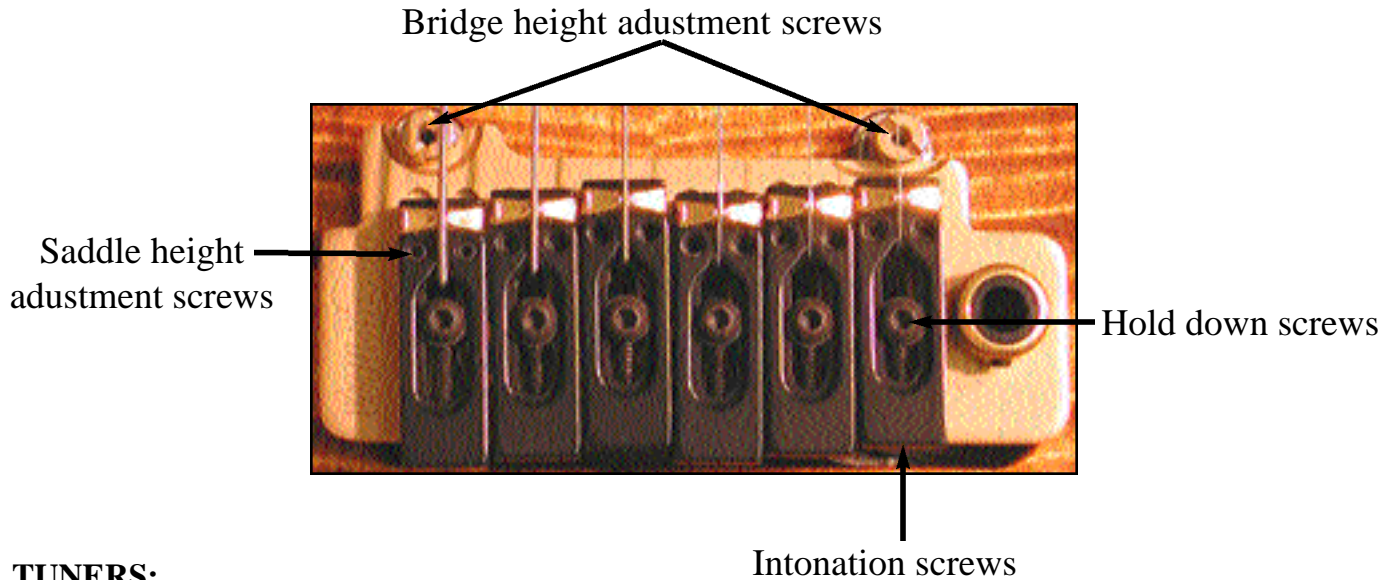

#### 4. TUNERS:

Your guitar has been equipped with Sperzel locking tuners. To change strings, turn the flywheel at the bottom of the tuner in a counter-clockwise direction (when looking at the tuner from the bottom), this will release the string. Remove the old string and thread a new one through the bridge. Line the string hole of the tuner up so the string will pass through the middle of the hole. Pull the string until it is just taut. Hold the string taut with one hand and turn the wheel on the bottom of the tuner in a clockwise direction to hold the string. Tighten the wheel only until it is snug, over tightening can result in jamming the locking mechanism. After locking the string in place, tune to pitch and remove excess string.

If the locking peg inside the tuner shaft gets stuck in the closed position, it can usually be freed by a firm tap on the top of the tuner with the plastic handle of a screwdriver. If this does not free the peg try pushing on the peg from both sides of the string hole with an ice pick or other pointed instrument, then try tapping the top again. To avoid the peg sticking, occasionally spray inside the string hole with a little silicone spray or WD-40.

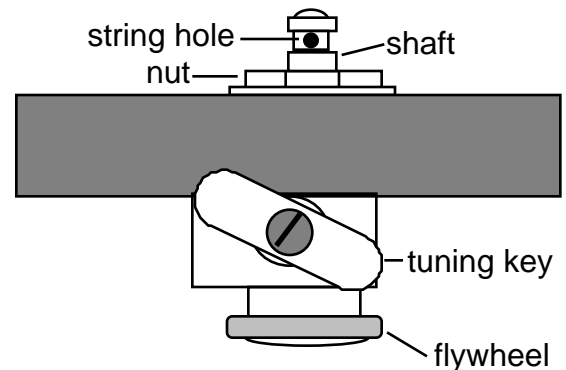

#### 5. TRUSS ROD:

The truss rod controls the amount of bow in the neck, known as the neck relief. A small amount of bow is desirable to allow the strings to vibrate without rattling on the frets. Only very slight adjustments of the truss rod should ever be needed. Over adjusting can cause severe damage to the neck. With this in mind, it is recommended that truss rod adjustments only be made by a qualified technician.

## 6. PICKUPS:

Seymour Duncan pickups are installed in all Brian Moore Guitars unless otherwise specified. An Alnico APH-1N is used in the neck position, and a JB Trembucker is used in the bridge position. In a hum-single-hum pick up configuration, a Duncan APS-2 is used for the single coil. Your guitar is set up to provide equal output between the neck and bridge pickups. To change the output level of the pickups, turn the height adjustment screws to raise or lower the pickup. It is recommended that the pickups be raised no closer than 1/8" from the string as this will interfere with the vibration of the string.

Pickup height adjustment screws

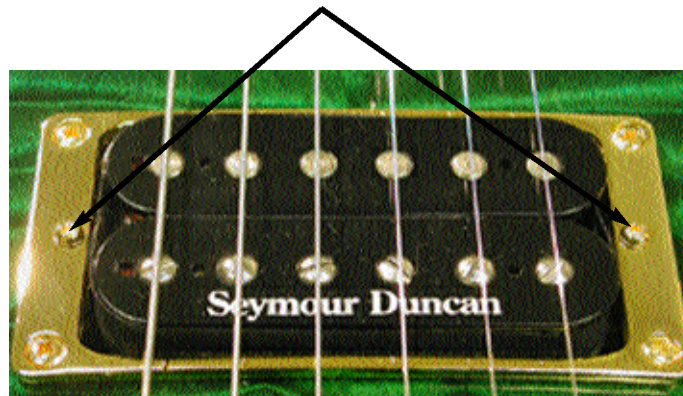

## 7. BRIDGES:

The most common bridges used in Brian Moore Guitars are The Wilkinson tremolo, Wilkinson fixed, Floyd Rose, and the Tonepros bridge.

**Wilkinson Vibrato:** The intonation adjustment screws on the Wilkinson are located at the back of each individual saddle. This is the case on both the standard and the piezo models. A hex wrench is supplied in your tool kit to fit these. Before adjusting intonation, be sure to loosen the hold down screws to allow the saddle to move freely. The height of the individual saddles is preset at the factory to match the radius of the fingerboard. It is not recommended to adjust individual saddle height. If you do find it necessary to adjust the saddle height, be sure to loosen the hold down screw first to avoid cracking the saddle. The action is adjusted by turning the bridge height adjustment screws, located at the front of the bridge.

### Wilkinson Vibrato Bridge



**Wilkinson Fixed:** The intonation screws are located at the

Intonation screws

back of the saddles, as in the tremolo bridge. The action on a fixed bridge is adjusted by changing the height of each individual saddle. Be sure to loosen the hold down screws to avoid cracking the saddle.

## Wilkinson Fixed Bridge

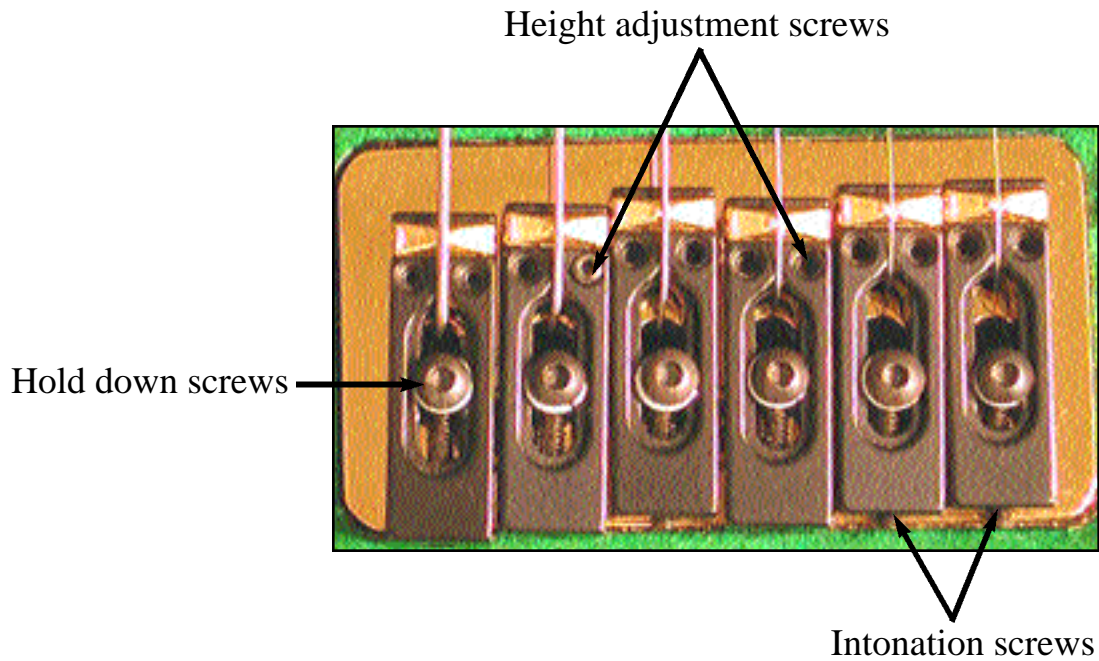

**Tonepros:** The intonation adjustment screws on a tonepros bridge are also located on the back of the bridge. These are adjustable with any small flat head screw driver. The action is adjusted by turning the to flywheels on the bottom of each end of the bridge. Be sure to loosen the locking screws before adjusting the action.

## Tonepros Bridge

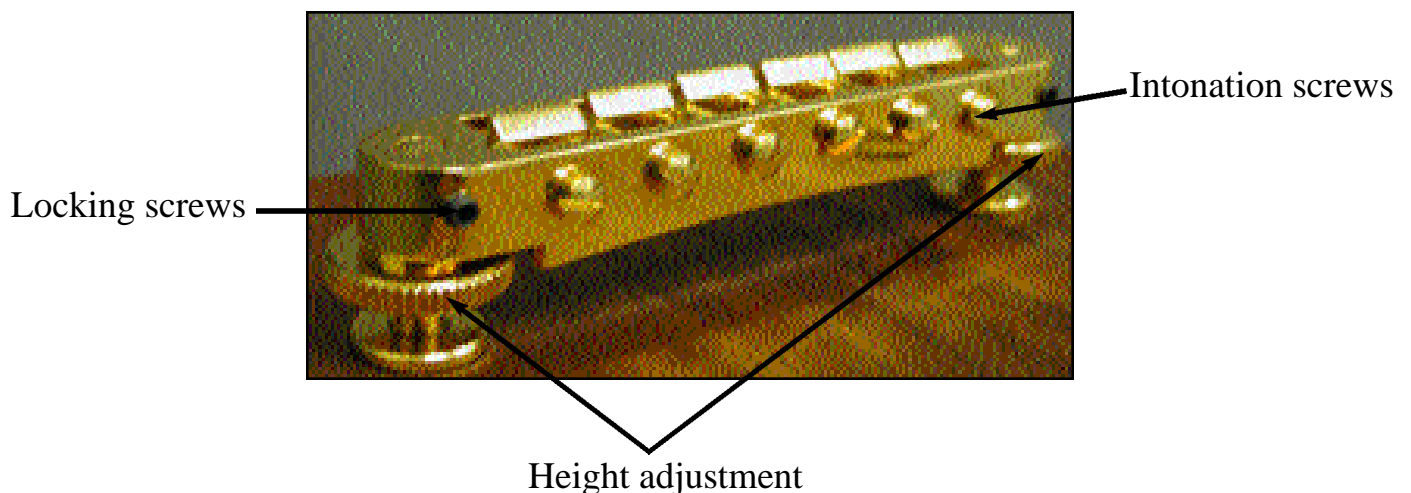

**Floyd Rose:** Action adjustment on a Floyd Rose bridge is achieved by turning the two hex screws at the front of the bridge. A hex wrench to fit these is supplied in your tool kit. Intonation adjustment of a Floyd Rose bridge is difficult without a specific tool available directly from Floyd Rose. It is recommended that without this intonation tool, intonation adjustment be done only by a qualified technician.

## Floyd Rose Bridge

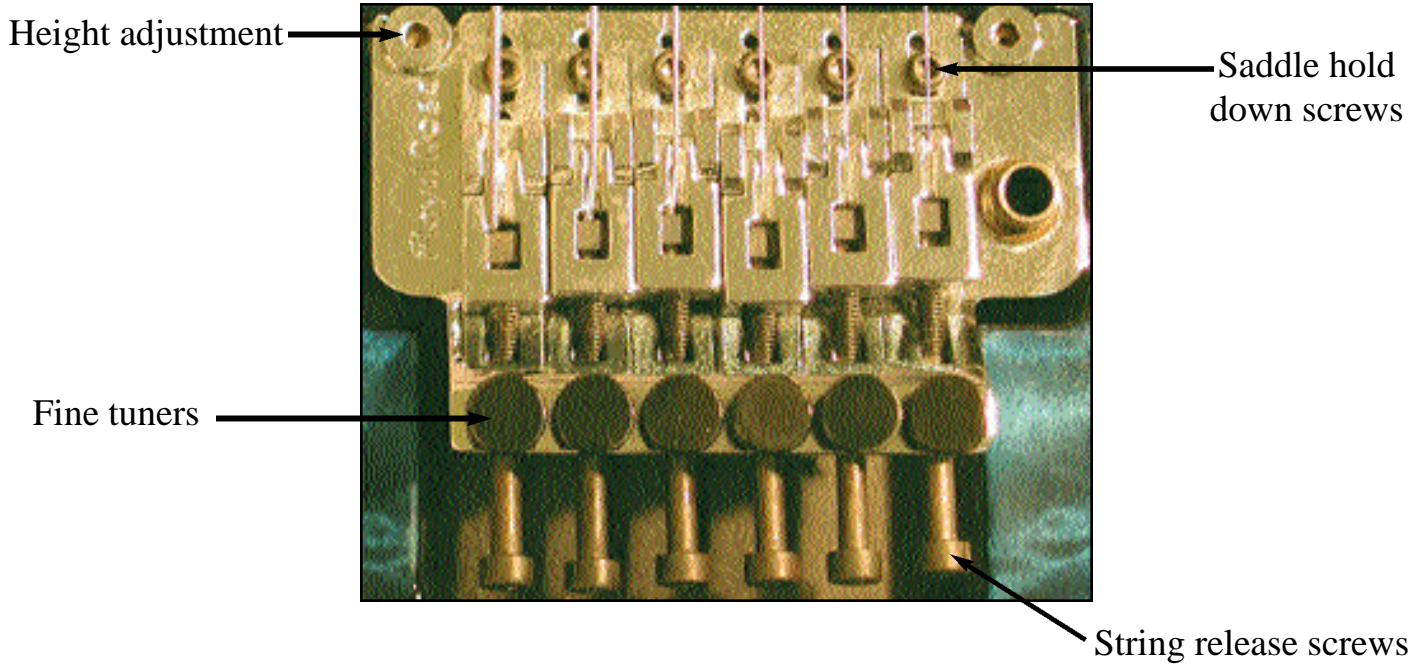

### **8. 13 PIN SYSTEM:**

Brian Moore guitars is on the cutting edge of guitar technology, offering 13 pin ready models that are compatible with most 13 pin sound modules, such as Roland's VG88 and GR33. These models offer on-board patch step up/step down control and guitar/synth/both switching through the 13 pin cable (see Controls Diagram pg. 6). Brian Moore Guitars uses the RMC 13 pin system which takes the signal directly from the piezo saddles for superior tracking.

The 13 pin jack is located at the bottom edge of the guitar. Many 13 pin sound modules have a setting for the input source. Be sure this is set to "piezo". It may also be necessary to set individual string sensitivity. Please consult your sound module's owners manual for instructions on this procedure.



### **9. REPAIRS AND WARRANTY:**

To obtain warranty service, contact your dealer, and have them obtain return authorization. For further information on warranty, refer to the warranty registration included with your guitar.

# CONTROLS GUIDE





# Pick up configuration: C-90

POSITION 1  
FRONT HUMBUCKER

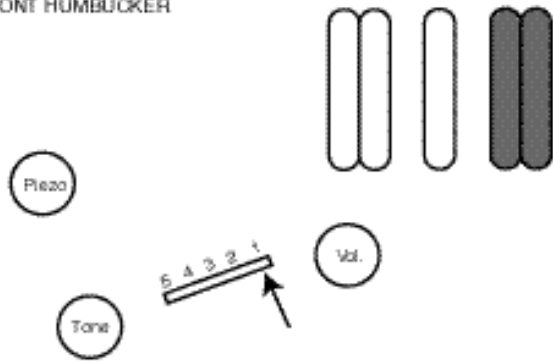

POSITION 2  
FRONT HUMBUCKER SPLIT  
AND MIDDLE

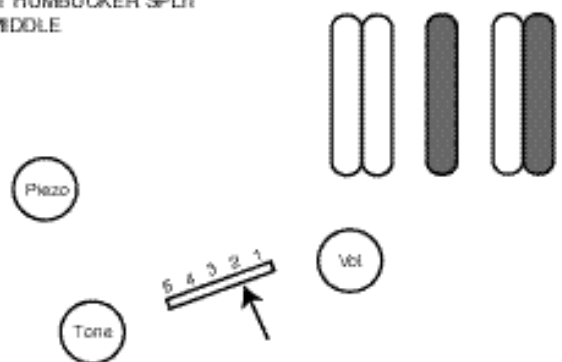

POSITION 3  
FRONT HUMBUCKER SPLIT  
REAR HUMBUCKER SPLIT

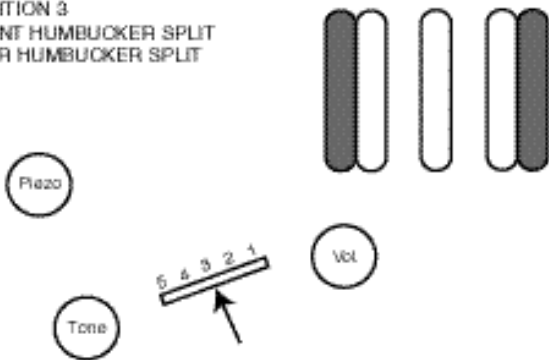

POSITION 4  
MIDDLE AND  
REAR HUMBUCKER SPLIT

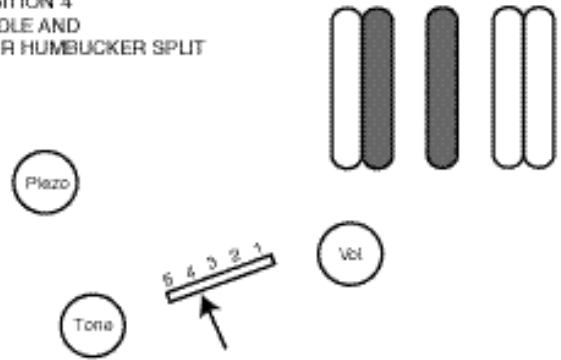

POSITION 5  
REAR HUMBUCKER

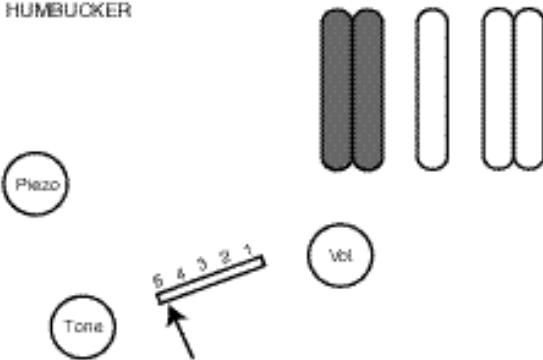

POSITION 1A  
BOTH HUMBUCKERS

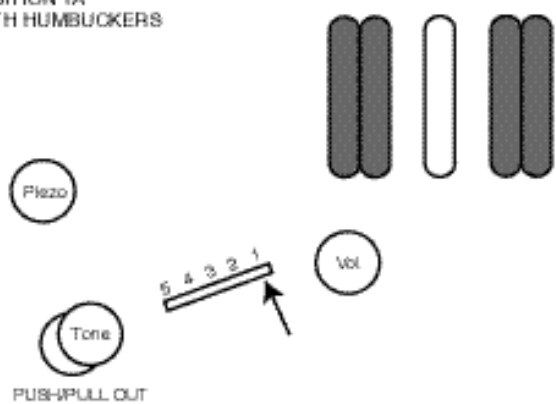

POSITION 2A  
FRONT HUMBUCKER SPLIT  
MIDDLE  
REAR HUMBUCKER

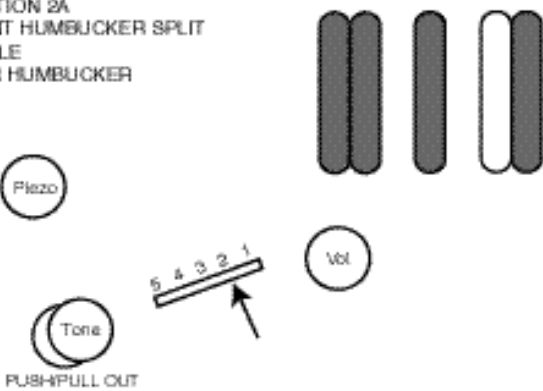

## HUM/SINGLE/HUM PICKUP CONFIGURATION

Neck Pickup Seymour Duncan -APH1  
Middle Pickup Seymour Duncan -APS2  
Bridge Pickup Seymour Duncan -JB

Brian Moore Guitars

Tech Support #: 845-486-0744



# Pick up configuration: C-55, DC-1

POSITION 1  
FRONT HUMBUCKER

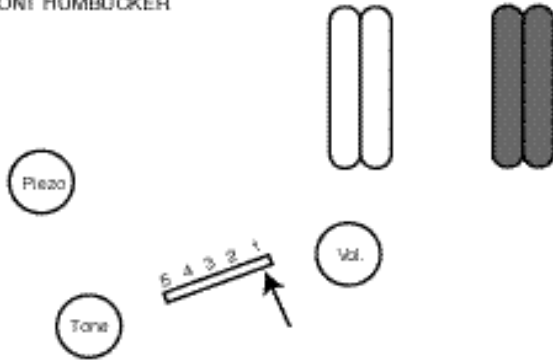

POSITION 2  
FRONT HUMBUCKER SPLIT

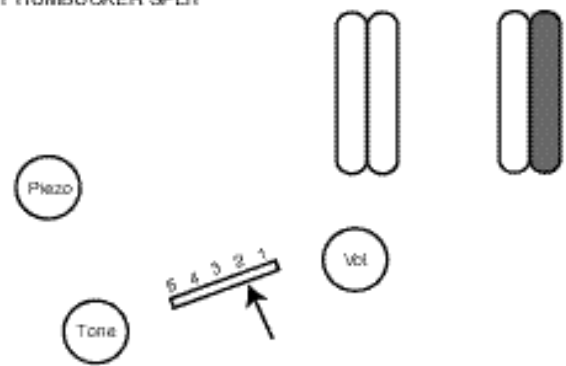

POSITION 3  
FRONT HUMBUCKER SPLIT  
REAR HUMBUCKER SPLIT

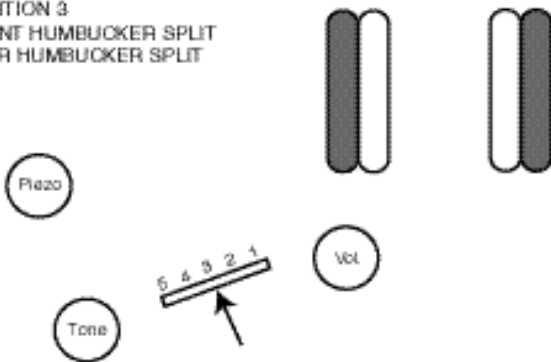

POSITION 4  
REAR HUMBUCKER SPLIT

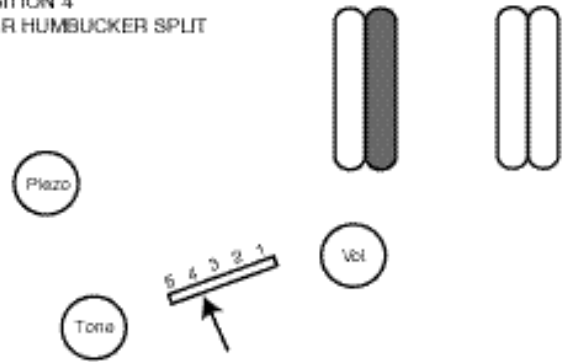

POSITION 5  
REAR HUMBUCKER

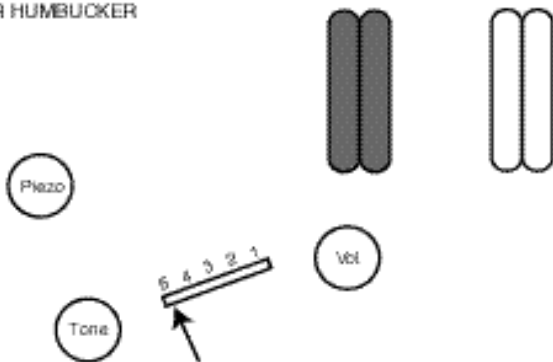

POSITION 1A  
BOTH HUMBUCKERS

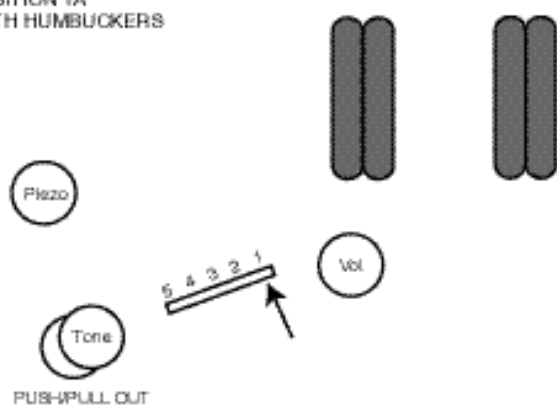

POSITION 2A  
FRONT HUMBUCKER SPLIT  
REAR HUMBUCKER

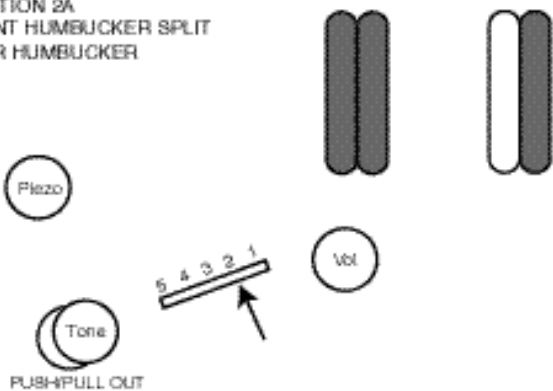

## HUM/HUM PICKUP CONFIGURATION

Neck Pickup Seymour Duncan - APH1

Bridge Pickup Seymour Duncan - JB

Brian Moore Guitars

Tech Support ☎ 845-486-0744

